

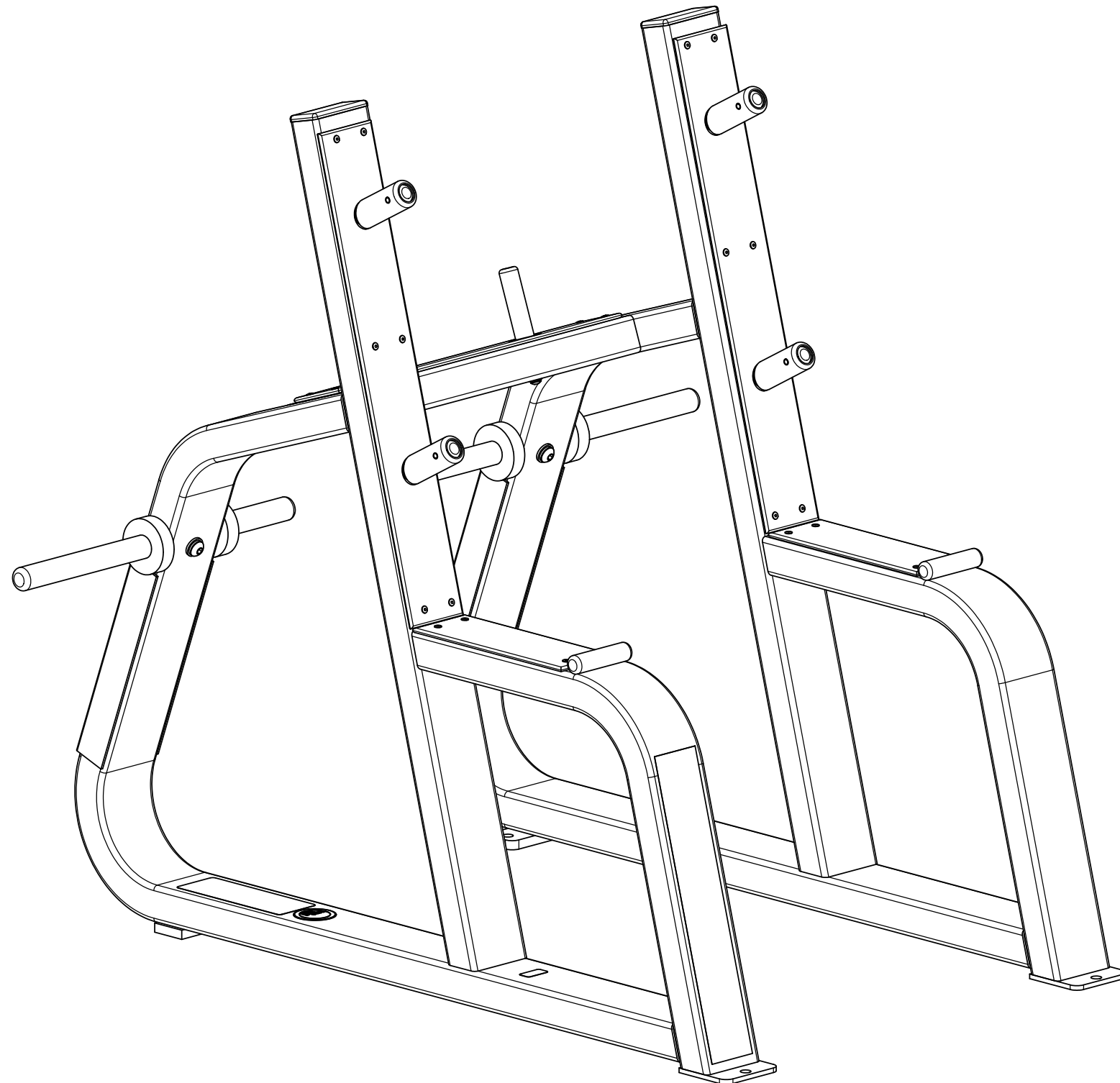

REVISIONS				
REV	ECN #	DESCRIPTION	REV. BY/DATE	APR. BY
A	-----	REDRAWN & UPDATED IN SOLIDWORKS	06/99	



ITEM NO.	QTY.	PART NO.	DESCRIPTION
1	1	207-SA-1	207 MAIN FRAME ASSY
2	1	AC1002	LABEL, "ICARIAN", 3 1/2 x 21 1/2
3	2	AC1057	CAP, BLACK PLASTIC, 2 x 4
4	4	AC1148	WEIGHT STACK BUMPER
5	1	AC1161	LABEL, ROUND, "MADE IN USA"
6	1	AC1164	LABEL, F.P.I. SERIAL NUMBER
7	1	AC1183	LABEL, "WARNING, SERIOUS INJURY..."
8	4	CP1012	CUT PIECE, UHMW, 1 1/2 OD x 1 ID x 3 5/8, 1 HOLE
9	2	CP1081	CUT PIECE, ABS CHANNEL, 1/8 x 2 x 4 1/4 x 12
10	1	CP1141 (L)	UHMW, 1/4 x 3 7/8 x 26 1/2, LEFT, 6 HOLES
11	1	CP1141 (R)	UHMW, 1/4 x 3 7/8 x 26 1/2, RIGHT, 6 HOLES
12	1	CP1142	UHMW, 1/4 x 3 1/2 x 21, 6 HOLES
13	2	CP1143	UHMW, 1/4 x 3 7/8 x 11, 4 HOLES
14	2	PF1247	STEEL BAR RND DIA 1 x (5 7/8), TAPPED 1 SIDE
15	2	PF1421	STEEL BAR RND DIA 1 1/4 x (20), 1 HOLE TAPPED
16	24	FA1049	RIVET, Dia 3/16 x 3/8-1/2 GRIP RANGE
17	4	FA1066	PIN, SPRING, DIA. 5/16 x 1 1/2
18	2	FA1067	BOLT, BUTTON HEAD, 5/16-18 x 1/2
19	2	FA1075	BOLT, BUTTON HEAD, 1/2-13 x 1
20	2	FA1106	WASHER, FLAT, 5/16 ID x 11/16 OD
21	2	FA1109	WASHER, FLAT, 1/2 ID x 1 1/16 OD
22	2	FA1116	WASHER, SPLIT, 5/16 ID
23	2	FA1119	WASHER, SPLIT, 1/2 ID
24	2	FA1123	STEEL SPACER, 5/8 OD x 1/2 ID x (3/8)

WEIGHT: 170 lbs.

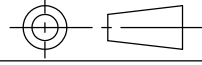
UNLESS OTHERWISE SPECIFIED DIMENSIONS ARE IN INCHES		 FITNESS PRODUCTS INTERNATIONAL ICARIAN FLITE ABENCH JADE STRETCH CENTER 12660 BRANFORD ST. SUN VALLEY, CA. 91352		TITLE SUPER CURL STAND (with weight pins)	SCALE 1:7
TOLERANCES ARE:					
FRACTIONS ± 1/32	DECIMALS .XX ± .01 .XXX ± .005	ANGLES ± 1°	DESIGNED BY KLS	01/95	SHEET 1 OF 2
THIRD ANGLE PROJECTION			MODELED BY VLE	06/99	
			DRAWN BY VLE	06/99	REV A
DO NOT SCALE DRAWING			APPROVED BY	SIZE B	DWG. NO. 207-ASSY

207 Super Curl Stand

Part Number	Description	Bubble Number
CW207SA1-211	ASSY,FRAME,MAIN,207,SKY WHITE	1.01
CW207SA1-221	ASSY,FRAME,MAIN,207,BLACK	1.02
CW207SA1-231	ASSY,FRAME,MAIN,207,RED	1.03
CW207SA1-241	ASSY,FRAME,MAIN,207,PLATINUM SPRKLE	1.04
CW207SA1-251	ASSY,FRAME,MAIN,207,SILVER	1.05
CW207SA1-261	ASSY,FRAME,MAIN,207,BLUE	1.06
CW207SA1-271	ASSY,FRAME,MAIN,207,CHARCOAL	1.07
CW207SA1-281	ASSY,FRAME,MAIN,207,CATHEDRAL GRAY	1.08
CW207SA1-291	ASSY,FRAME,MAIN,207,SILVER VIEN	1.09
CW207SA1-311	ASSY,FRAME,MAIN,207,STONE HG	1.11
CW207SA1-321	ASSY,FRAME,MAIN,207,TITANIUM HG	1.12
CW207SA1-331	ASSY,FRAME,MAIN,207,WHITE GLOSS	1.13
CW207SA1-341	ASSY,FRAME,MAIN,207,BLACK ONYX	1.14
CW207SA1-351	ASSY,FRAME,MAIN,207,LIGHT BRONZE	1.15
CW207SA1-361	ASSY,FRAME,MAIN,207,SAPPHIRE BLUE	1.16
CWAC1002-101	LABEL, "ICARIAN", 3 X 16 3/8	2
CW11311-102	ENDCAP, REC TUBE, 2X4, BLK PLASTIC	3
CW12402-101	BUMPER, WEIGHT STACK, BLK RUBBER	4
CWAC1164-101	LABEL, F.P.I. SERIAL NUMBER	6
CWCP1012-101	CUT PIECE, UHMW, 1 1/2 OD X 1 ID X	8
CWCP8112-000	CUT PIECE, ABS CHANNEL,1/8 X 2 X 4	9
CWCP1141-101	CUT PIECE, UHMW, 1/4 X 3 7/8 X 26 1	10
CWCP1141-102	CUT PIECE, UHMW, 1/4 X 3 7/8 X 26 1	11
CWCP1142-101	CUT PIECE, UHMW, 1/4 X 3 1/2 X 21,	12
CWCP1143-101	CUT PIECE, UHMW, 1/4 X 3 7/8 X 11,	13
CWPF1247-741	BAR,STEEL, RND, DIA 1" X (5 7/8), T	14
CWPF1421-741	BAR,STEEL RND, DIA 1 1/4" X (20), 1	15
CW10175-108	RIVIT, DIA .187, .376-.500 GRIP RAN	16
CWLDNN031-150	PIN, ROLL, DIA. 5/16 X 1 1/2	17
CWTAYN031-050	SCREW, BUTTON HEAD, BLK XYLAN,5/16	18
CWTAYN050-100	SCREW, BUTTON HEAD, BLK XYLAN, 1/2	19
CWWBKN031-007	WASHER, FLAT, TYPE A, SAE, 5/16 ID	20
CWWBKN050-010	WASHER, FLAT, TYPE A, SAE, 1/2 ID X	21
CWWALYN031-008	WASHER, SPLIT, 5/16 ID, BL	22
CWWALYN050-013	WASHER, SPLIT, 1/2 ID, BLK XYLAN	23
CWFA1123-901	SPACER, STEEL,5/8 OD X 1/2 ID X 3/8	24
CW30010-101	LABEL,WARNING STRENGTH	25
CW31756-101	LABEL, PRECOR USA ICARIAN LINE	26
CWAC1177-101	FLOOR PROTECTOR, RUBBER, 4.563 X 4.	501
CWAC1178-101	FLOOR PROTECTOR, RUBBER, 2.563 X 6.	502

207 Super Curl Stand

Part Number	Description	Bubble Number
CW207SA1-211	ASSY,FRAME,MAIN,207,SKY WHITE	1.01
CW207SA1-221	ASSY,FRAME,MAIN,207,BLACK	1.02
CW207SA1-231	ASSY,FRAME,MAIN,207,RED	1.03
CW207SA1-241	ASSY,FRAME,MAIN,207,PLATINUM SPRKLE	1.04
CW207SA1-251	ASSY,FRAME,MAIN,207,SILVER	1.05
CW207SA1-261	ASSY,FRAME,MAIN,207,BLUE	1.06
CW207SA1-271	ASSY,FRAME,MAIN,207,CHARCOAL	1.07
CW207SA1-281	ASSY,FRAME,MAIN,207,CATHEDRAL GRAY	1.08
CW207SA1-291	ASSY,FRAME,MAIN,207,SILVER VIEN	1.09
CW207SA1-311	ASSY,FRAME,MAIN,207,STONE HG	1.11
CW207SA1-321	ASSY,FRAME,MAIN,207,TITANIUM HG	1.12
CW207SA1-331	ASSY,FRAME,MAIN,207,WHITE GLOSS	1.13
CW207SA1-341	ASSY,FRAME,MAIN,207,BLACK ONYX	1.14
CW207SA1-351	ASSY,FRAME,MAIN,207,LIGHT BRONZE	1.15
CW207SA1-361	ASSY,FRAME,MAIN,207,SAPPHIRE BLUE	1.16
CWAC1002-101	LABEL, "ICARIAN", 3 X 16 3/8	2
CW11311-102	ENDCAP, REC TUBE, 2X4, BLK PLASTIC	3
CW12402-101	BUMPER, WEIGHT STACK, BLK RUBBER	4
CWAC1164-101	LABEL, F.P.I. SERIAL NUMBER	6
CWCP1012-101	CUT PIECE, UHMW, 1 1/2 OD X 1 ID X	8
CWCP8112-000	CUT PIECE, ABS CHANNEL,1/8 X 2 X 4	9
CWCP1141-101	CUT PIECE, UHMW, 1/4 X 3 7/8 X 26 1	10
CWCP1141-102	CUT PIECE, UHMW, 1/4 X 3 7/8 X 26 1	11
CWCP1142-101	CUT PIECE, UHMW, 1/4 X 3 1/2 X 21,	12
CWCP1143-101	CUT PIECE, UHMW, 1/4 X 3 7/8 X 11,	13
CWPF1247-741	BAR,STEEL, RND, DIA 1" X (5 7/8), T	14
CWPF1421-741	BAR,STEEL RND, DIA 1 1/4" X (20), 1	15
CW10175-108	RIVIT, DIA .187, .376-.500 GRIP RAN	16
CWLDNN031-150	PIN, ROLL, DIA. 5/16 X 1 1/2	17
CWTAYN031-050	SCREW, BUTTON HEAD, BLK XYLAN,5/16	18
CWTAYN050-100	SCREW, BUTTON HEAD, BLK XYLAN, 1/2	19
CWWBKN031-007	WASHER, FLAT, TYPE A, SAE, 5/16 ID	20
CWWBKN050-010	WASHER, FLAT, TYPE A, SAE, 1/2 ID X	21
CWWALYN031-008	WASHER, SPLIT, 5/16 ID, BL	22
CWWALYN050-013	WASHER, SPLIT, 1/2 ID, BLK XYLAN	23
CWFA1123-901	SPACER, STEEL,5/8 OD X 1/2 ID X 3/8	24
CW30010-101	LABEL,WARNING STRENGTH	25
CW31756-101	LABEL, PRECOR USA ICARIAN LINE	26
CWAC1177-101	FLOOR PROTECTOR, RUBBER, 4.563 X 4.	501
CWAC1178-101	FLOOR PROTECTOR, RUBBER, 2.563 X 6.	502